

Smarter Thinking - Smarter Solutions



JEROS

2018

JEROS BASIC-products *PRICE LIST* 2018

01.01.18 - 31.12.18



Smarter Solutions

JEROS Tray Cleaner without oiling Model 6007 + 6014

Valid from 01.01.18 to 31.12.18

Gross Prices



Basic Model 6007	Discount group A	EUR
- Pre-scraper		
- Entering rollers		
- Steel brush rollers or nylon brush (Optional)		
- Extension rollers		
- Cleaning system (except if with nylon brushes)		
- Stainless steel chassis		
- Machine height 800 mm - 1050 mm (Optional)		
Type = Tray width		
508 = 125 mm - 500 mm		9.900,-
658 = 501 mm - 650 mm		9.900,-
828 = 651 mm - 820 mm		10.900,-
1078 = 821 mm - 1070 mm		12.900,-

JEROS Tray Cleaner Model 6007 / 6014

Capacity: 100 trays within 6 min.
 Current rating: 5,8 Amp v.230/240V
 3,4 Amp v.400/415V
 Energi conection: 3 x 230/240V+N+E
 3 x 400/415V+N+E

Basic Model 6014	Discount group A	EUR
- Pre-scraper		
- Entering rollers		
- Steel brush rollers or nylon brush (Optional)		
- Extension rollers		
- Cleaning system (except if with nylon brushes)		
- Nylon brushes for end-cleaning		
- Stainless steel chassis		
- Machine height 800 mm - 1050 mm (Optional)		
Type = Tray width		
508 = 125 mm - 460 mm		13.700,-
658 = 461 mm - 610 mm		13.700,-
828 = 611 mm - 780 mm		14.800,-
1078 = 781 mm - 1030 mm		15.800,-

Colour Code

- Pre scraper system
- Entering rollers
- ▲ Cleaning system (Only if with steel brushes)
- Steel brush- or nylon brush rollers
- Extension rollers
- ▲ Finishing brush
- Quickly detachable nylon brushes

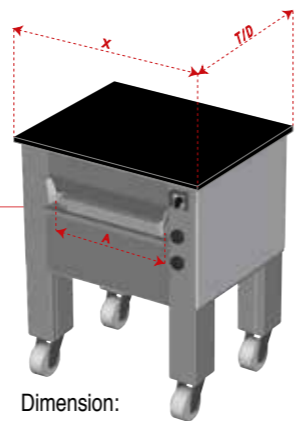

Dimension:
(H x X x D)
800 - 1050 mm x "X" x 630 mm
A = tray width

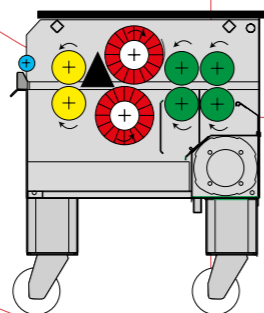

Model 6007

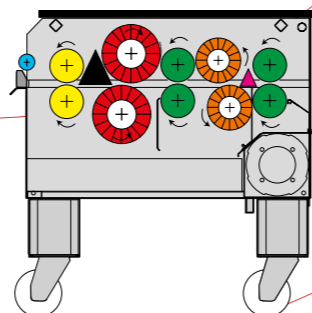

Model 6014

Options/Accessories	Discount group B	EUR
Roller for 2 tray sizes		1.275,-
Tray trolley, (kit - light model)		479,-
Tray trolley stainless steel		599,-
Tray trolley with fedre = noise reduction*		911,-
*only for tray cleaners with a min. height of 95 cm.		
Price for stainless steel brushes on request		

UK.01.18



JEROS® A/S

Nyborgvej 8
DK-5750 Ringe

Tel: +45 63 62 39 13
Fax: +45 62 62 33 01

jeros@jeros.com
www.jeros.com

JEROS Tray Cleaner with oiling Model 6011 + 6015

Valid from 01.01.18 to 31.12.18

Gross Prices



Basic Model 6011	Discount group A	EUR
- Pre-scraper		
- Entering rollers		
- Steel brush rollers or nylon brush (Optional)		
- Extension rollers		
- Cleaning system (except if with nylon brushes)		
- Automatical oiling		
- Stainless steel chassis		
- Machine height 800 mm - 1050 mm (Optional)		
Type = Tray width		
508 = 125 mm - 500 mm		10.900,-
658 = 501 mm - 650 mm		10.900,-
828 = 651 mm - 820 mm		12.900,-
1078 = 821 mm - 1070 mm		13.900,-

JEROS Tray Cleaner Model 6011 / 6015

Capacity: 100 trays within 6 min.
 Current rating: 5,8 Amp v.230/240V
 3,4 Amp v.400/415V
 Energi conection: 3 x 230/240V+N+E
 3 x 400/415V+N+E

Basic Model 6015	Discount group A	EUR
- Pre-scraper		
- Entering rollers		
- Steel brush rollers or nylon brush (Optional)		
- Extension rollers		
- Cleaning system (except if with nylon brushes)		
- Nylon brushes for end-cleaning		
- Automatical oiling		
- Stainless steel chassis		
- Machine height 800 mm - 1050 mm (Optional)		
Type = Tray width		
508 = 125 mm - 460 mm		15.200,-
658 = 461 mm - 610 mm		15.200,-
828 = 611 mm - 780 mm		16.800,-
1078 = 781 mm - 1030 mm		18.100,-

Colour Code

- Pre scraper system
- Entering rollers
- ▲ Cleaning system (Only if with steel brushes)
- Precision grounded steel brush rollers
- Extension rollers
- Quickly detachable nylon brushes
- ▲ Finishing brush
- Automatic oiling

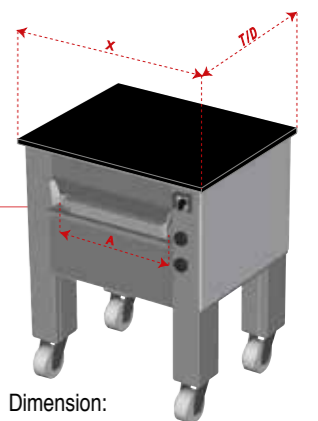

Dimension:
(H x X x D)
800 - 1050 mm x "X" x 630 mm
A = tray width

UK.01.18

Options/Accessories	Discount group B	EUR
Roller for 2 tray sizes		1.275,-
Tray trolley, (kit - light model)		479,-
Tray trolley stainless steel		599,-
Tray trolley with fedre = noise reduction*		911,-
*only for tray cleaners with a min. height of 95 cm.		
Price for stainless steel brushes on request		

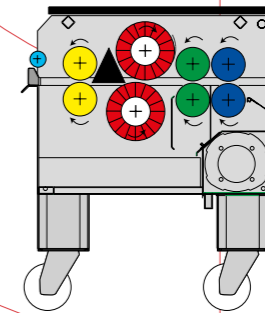

Model 6011

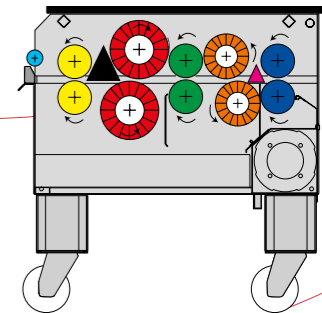

Model 6015

JEROS® A/S

Nyborgvej 8
DK-5750 Ringe

Tel: +45 63 62 39 13
Fax: +45 62 62 33 01

jeros@jeros.com
www.jeros.com

JEROS Tray Cleaner without oiling Model 9014

Valid from 01.01.18 to 31.12.18

Gross Prices



Basic Model 9014	Discount group A	EUR
- Double pre scraper system		
- In / outlet system		
- Precision ground nylon brushes		
- Quickly detachable nylon brushes		
- Quickly detachable hole brushes		
- Aqua clean - water proof		
- Complete stainless steel		
- Machine height 800 mm - 1050 mm (Optional)		
Type = Tray width		
508 = 125 mm - 460 mm		15.150,-
658 = 461 mm - 610 mm		15.150,-
828 = 611 mm - 780 mm		16.200,-
1078 = 781 mm - 1030 mm		17.200,-

JEROS Tray Cleaner Model 9014

Capacity: 100 trays within 6 min.
 Current rating: 5,8 Amp v.230/240V
 3,4 Amp v.400/415V
 Energi conection: 3 x 230/240V+N+E
 3 x 400/415V+N+E

Colour Code

- Double pre scraper system
- In-outlet system
- Precision ground nylon brushes*
Optional stainless steel brushes on request!
- Quickly detachable hole brushes
- Quickly detachable nylon brushes
- Finishing brush

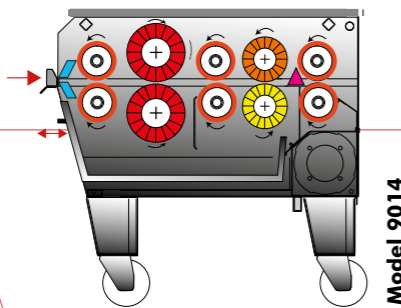

Model 9014

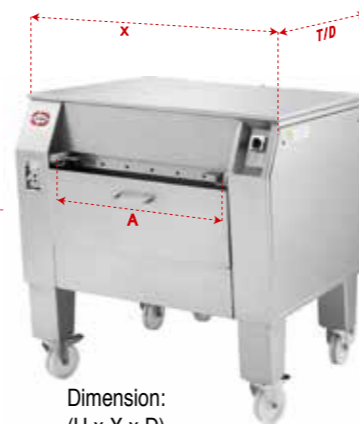

Dimension:
 (H x X x D)
 800 - 1050 mm x "X" x 925 mm
 A = tray width

Options/Accessories	Discount group B	EUR
Tray trolley, (kit - light model)		479,-
Tray trolley stainless steel		599,-
Tray trolley with fedre = noise reduction*		911,-
<small>*only for tray cleaners with a min. height of 95 cm.</small>		
Price for stainless steel brush on request		

JEROS Tray Cleaner with oiling Model 9011 + 9015

Valid from 01.01.18 to 31.12.18

Gross Prices



Basic Model 9011	Discount group A	EUR
- Double pre scraper system		
- In / outlet system		
- Precision ground nylon brushes		
- Aqua clean - water proof		
- Complete stainless steel		
- Automatical oiling		
- Machine height 800 mm - 1050 mm (Optional)		
Type = Tray width		
508 = 125 mm - 460 mm		13.250,-
658 = 461 mm - 610 mm		13.250,-
828 = 611 mm - 780 mm		15.350,-
1078 = 781 mm - 1030 mm		16.650,-

JEROS Tray Cleaner Model 9011 / 9015

Capacity: 100 trays within 6 min.
 Current rating: 5,8 Amp v.230/240V
 3,4 Amp v.400/415V
 Energi conection: 3 x 230/240V+N+E
 3 x 400/415V+N+E

Basic Model 9015	Discount group A	EUR
- Double pre scraper system		
- In / outlet system		
- Precision ground nylon brushes		
- Quickly detachable nylon brushes		
- Quickly detachable hole brushes		
- Aqua clean - water proof		
- Complete stainless steel		
- Automatical oiling		
- Machine height 800 mm - 1050 mm (Optional)		
Type = Tray width		
508 = 125 mm - 460 mm		16.650,-
658 = 461 mm - 610 mm		16.650,-
828 = 611 mm - 780 mm		18.200,-
1078 = 781 mm - 1030 mm		19.400,-

Colour Code

- Double pre scraper system
- In-outlet system
- Precision ground nylon brushes*
Optional stainless steel brushes on request!
- Quickly detachable hole brushes
- Quickly detachable nylon brushes
- Finishing brush
- Automatic oil greasing unit
- Waste drawer

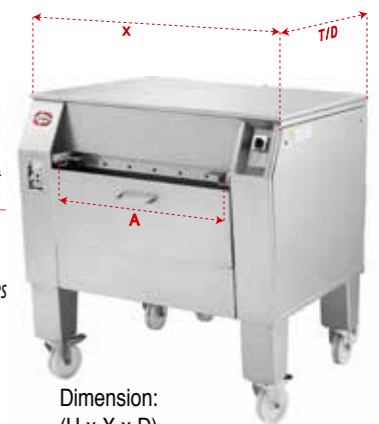

Dimension:
 (H x X x D)
 800 - 1050 mm x "X" x D:
 Model 9011 825 mm
 Model 9015 925 mm
 A = tray width

Options/Accessories	Discount group B	EUR
Tray trolley, (kit - light model)		479,-
Tray trolley stainless steel		599,-
Tray trolley with fedre = noise reduction*		911,-
<small>*only for tray cleaners with a min. height of 95 cm.</small>		
Price for stainless steel brush on request		

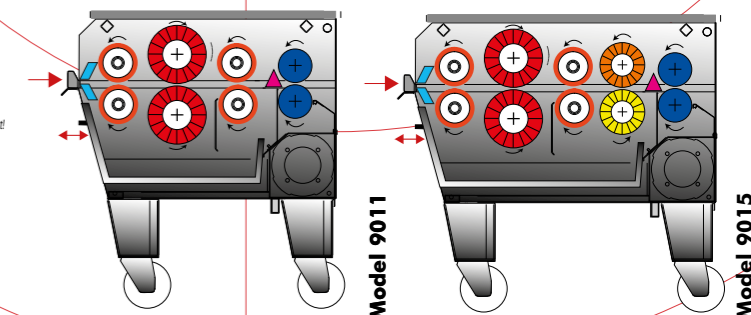

Model 9011

Model 9015

UK.01.18

UK.01.18



JEROS® A/S

Nyborgvej 8
 DK-5750 Ringe

Tel: +45 63 62 39 13
 Fax: +45 62 62 33 01

jeros@jeros.com
 www.jeros.com

JEROS® A/S

Nyborgvej 8
 DK-5750 Ringe

Tel: +45 63 62 39 13
 Fax: +45 62 62 33 01

jeros@jeros.com
 www.jeros.com

JEROS Dish Washer Model 8100 ACI

Valid from 01.01.18 to 31.12.18

Gross Prices

Discount group B !!!



JEROS Dish Washer in general

Wash time: 1 / 2 / 4 min.

Wash temperatur: 55°C

End rinse temperatur: 85°C

Rinse time: 20 sek.

Price EURO	Discount group B	8100
Basic Model 8100 ACI		6.500
A = Automatic soap dosage		Inkl.
C = End-rinse pump		inkl.
I = Isolated lid, wash- & rinse tank		inkl.
Wash area		
Width		500
Height		405
Depth		500
Capacity		
Gastronorm tray 500x500		1
General Data		
Wash tank		40
Rinse tank		13
Water consumption per wash		3,5
Wash pump capacity		500
Wash temperature		55°C
Rinse temperature		85°C
Wash time min.		1+2+4
Wash pressure		0,9 bar
Rinse pressure		1,1 bar
Wash pump kW		1,1 kW
Current rating		16 Amp
Connection		8,5 kW
Machine dimension H1 x H2 x W x D		1989 x 1561 x 600 x 749

JEROS Utensil Washer Model 8105 c

Valid from 01.01.18 to 31.12.18

Gross Prices

Discount group B !!!



JEROS Utensil Washer in general

Wash time: 3 / 3 / 6 min.

Wash temperatur: 55°C

End rinse temperatur: 85°C

Rinse time: 20 sec.

Price EURO	Discount group B	8105
Basic Model 8105 C		6.295
A = Automatic soap dosage		520
Wash area		
Width		540
Height		600
Depth		635
Capacity		
Euronorm crates 400x600		1
Plates 600x400		15
Plates 600x460		15
Plates 600x800		-
Gastronorm tray 500x500		1
40 L Bowl H 457x Ø 514		1
60 L Bowl H 511 x Ø 575		1
General Data		
Wash tank		34
Rinse tank		14,5
Water consumption per wash		5
Wash pump capacity		500
Wash temperature		55°C
Rinse temperature		85°C
Wash time min.		3+3+6
Wash pressure		0,9 bar
Rinse pressure		1,1 bar
Wash pump kW		1,1 kW
Current rating		16 Amp
Connection		8,5 kW
Machine dimension H1 x H2 x W x D		2100 x 1631 x 600 x 745

JEROS Combi Washer Model 950 / 960 ACI

Discount group B !!!

Price EURO	Discount group B	950	960
Basis model ACI		3.425	4.150
A = Automatic soap dosage		Inkl.	Inkl.
C = End-rinse pump		Inkl.	Inkl.
Wash area			
Width		500	500
Height		380	380
Depth		500	600
Capacity			
Gastronorm tray 500 x 500		1	1
Euronorm crate 400 x 600		-	1
Plates 400 x 600		-	8



Machine dimension H x W x D:
Model 950
820x600x600
Model 960
820x600x700

JEROS® A/S

Nyborgvej 8
DK-5750 Ringe

Tel: +45 63 62 39 13
Fax: +45 62 62 33 01

jeros@jeros.com
www.jeros.com

JEROS® A/S

Nyborgvej 8
DK-5750 Ringe

Tel: +45 63 62 39 13
Fax: +45 62 62 33 01

jeros@jeros.com
www.jeros.com



JEROS Utensil Washer 91xx-series

Valid from 01.01.18 to 31.12.18

Gross Prices

Price EURO	Discount group A	9110	9115	9117	9120	9130
Basic Model 91xx CI		9.950	12.175	13.775	18.925	20.775
A = Automatic soap dosage		520	520	520	520	520
B = Integrated mixing tap		425	425	425	425	425
C = End-rinse pump		inkl.	inkl.	inkl.	inkl.	inkl.
D = Rinsehose		230	230	230	230	230
I = Isolated lid, wash- & rinsetank		inkl.	inkl.	inkl.	inkl.	inkl.
S = Steam converter		2.200	2.200	2.200	2.450	2.450
W=Wheels, Machine mounted on		250	250	250	250	250
P = Puls wash		895	895	-	-	-
E = Integrated shower tap		675	675	675	675	675
XH = Extra wash height +230 mm		1.025	1.025		4.050 (inkl. H)	-
H = Automatic lid opening system		-	-	-	3.095	3.095
F = Main switch		-	-	-	105	105
T = Steam connection Wash tank		1.025	1.025	1.025	1.025	1.025
Wash area						
Width		690	810	830	1010	1290
Height		590	590	645	645	645
Depth		635	635	635	635	735
Capacity						
Euronorm crates 400x600		1	2	2	2	3
Plates 600x400		15	30	30	30	45
Plates 600x460		15	15	15	30	30
Plates 600x800		-	15	15	15	15
Gastronorm tray 500x500		1	1	1	2	2
60 L - Bowl H 511 x Ø 575		1	1	1	1	2
80 L - Bowl H 515 x Ø 645		-	-	1	1	2
General Data						
Wash tank		51	51	64	86	128
Rinse tank		11	11	25	25	30
Water consumption per wash		4	4	8	10	12
Wash pump capacity		600	950	600	2 x 600	600 + 950
Wash temperature		58°C	58°C	58°C	58°C	58°C
Rinse temperature		85°C	85°C	85°C	85°C	85°C
Wash time min.		3+3+6	3+3+6	3+3+6	3+3+6	3+3+6
Wash pressure		1,2 bar	1,4 bar	0,9-1,2 bar	0,8-1,2 bar	0,8-1,3 bar
Rinse pressure		1,1 bar	1,1 bar	1,1 bar	1,1 bar	1,1 bar
Wash pump kW		1,4 kW	2 kW	2 kW	2 x 1,4 kW	1,4 + 2 kW
Current rating		16 Amp	16 Amp	25 Amp	32 Amp	32 Amp
Connection		6,5 kW	6,5 kW	12 kW	13,5 kW	16,5 kW
Machine dimension H1 x H2 x W x D		2100 x 1631 x 840 x 855	2100 x 1631 x 960 x 855	2100 x 1631 x 1085 x 755	2100 x 1631 x 1280 x 755	2100 x 1631 x 1555 x 955

UK.01.18



JEROS® A/S

Nyborgvej 8
DK-5750 Ringe

Tel: +45 63 62 39 13
Fax: +45 62 62 33 01

jeros@jeros.com
www.jeros.com

JEROS Utensil Washer 91xx-series

Valid from 01.01.18 to 31.12.18

Gross Prices



JEROS Control Panel

- 01) Machine ON / OFF button.
- 02) Button to empty wash tank.
- 03) Flush hose ON / OFF button.
- 04A) Button "PULS" wash system ON / OFF 9110/9115
- 04B) Button for high / low washing pressure 9117/9120/9130
- 05) Wash programme 1 - "ECO wash" (3 min. at reduced temperature/ less soap)
- 06) Wash programme 2 (standard 3 min)
- 07) Wash programme 3 (standard 6 min)
- 08) LEDs indicate the machine is in work progress
- 09) Indicator: wash program completed
- 10) Indicator: soap dosage
- 11) Indicator: time for service inspection
- 12) Display temperature wash water/ wash time / rinse time / error code
- 13) Display temperature rinse water / error code

UK.01.18



Option E =
Integrated shower tap

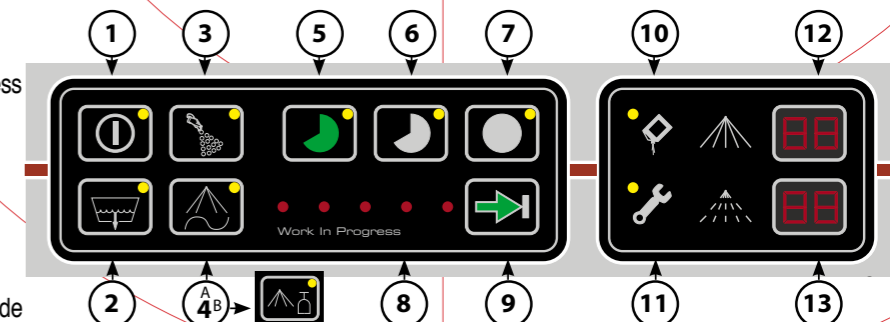

JEROS Utensil Washer in general

- Wash time: 3 / 3 / 6 min.
- Eco Wash: 3 min. less soap/ less temperature.
- Puls Wash Option 9110 + 9115
- High/low wash pressure ... 9117, 9120, 9130
- Wash temperatur: 55°C
- End rinse temperatur: 85°C
- Rinse time: 20 sec.

JEROS® A/S

Nyborgvej 8
DK-5750 Ringe

Tel: +45 63 62 39 13
Fax: +45 62 62 33 01

jeros@jeros.com
www.jeros.com

JEROS Accessories

Accessories

Discount group B

Valid from 01.01.18 to 31.12.18

Gross Prices

5990-0008

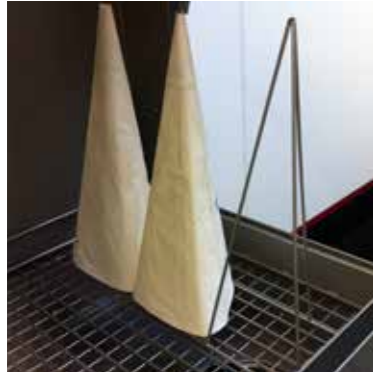

Spray bag rack for 3 spray bag
EUR 75,-

5990-0010



Tray rack for 7 trays
EUR 65,-

5990-0009



Tray rack for 15 trays
EUR 105,-

5990-0011



Basket rack, 16 - 18 pc.
50x50 cm
EUR 40,-

5990-0016

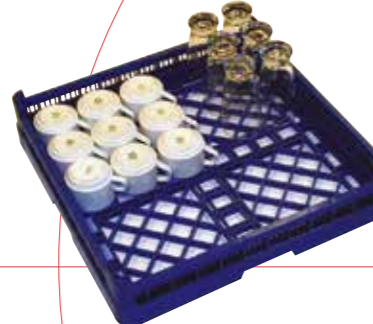

Basket for cups/glasses
50x50 cm
EUR 40,-

5990-0012



Basket for small parts
50x50 cm
EUR 40,-

5990-0014



Basket for small parts
25x50 cm
EUR 27,-

5990-0013

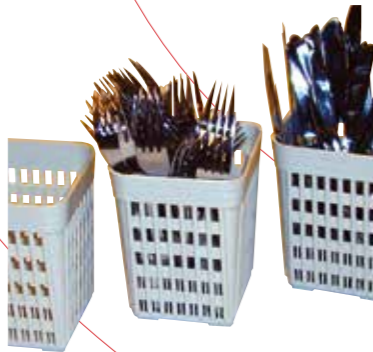

Cutlery rack
EUR 15,-

5990-0015



Cutlery rack 8 rooms
EUR 27,-

JEROS® A/S

Nyborgvej 8
DK-5750 Ringe

Tel: +45 63 62 39 13
Fax: +45 62 62 33 01

jeros@jeros.com
www.jeros.com

JEROS Accessories

Pre rinse / Tables / Water softener

Valid from 01.01.18 to 31.12.18

Gross Prices



Pre-Wash table
Easy removable filter system

Table L x D	Discount group B	Euro
750 x 790		1.045
900 x 790		1.075
1200 x 790		1.225
1500 x 790		1.525
Additional price /max 2000 mm		395
Options		
Sink		950
Special Sink		1.100
Table shower tap Mora		600
Wall shower tap Mora		695
Table shower tap Echtermann		965
Wall shower tap Echtermann		965

Kinetic	Discount group B	EURO
Model Kinetic HT-613	5990-0000	1.750
Mounting Kit	5990-0001	165
Salt 8 kg	5990-0002	30
In general		
No electrical connection		
No programming		
Low water and salt consumption		
100% corrosion-free material		
Quick and easy installation		



JEROS® A/S

Nyborgvej 8
DK-5750 Ringe

Tel: +45 63 62 39 13
Fax: +45 62 62 33 01

jeros@jeros.com
www.jeros.com



JEROS Universal Machine Crate Washer

Valid from 01.01.18 to 31.12.18

Gross Prices

Price EURO	Discount group A	200	200XL
Basic Model		17.800	23.200
A = Automatic soap dosage		975	975
M = One-man-operation		1.250	1.250
N = After rinse heater 2x9 kW (+30°C)		1.900	1.900
L = Automatic dosage pump for after rinse liquid		795	795
SV = Extra 2,7 kW wash pump		975	inkl.
Q = Adjustable conveyor speed		640	640
R = Mesh-tray stainless steel conveyer belt		1.725	1.725
T = Steam connection wash tank		1.025	1.025
Wash area			
Width		460	650
Height		470	470
Capacity			
Euronorm crates 400x600		150-230	250-300
Drying Unit 200 TD			
200 TD		13.500	14.300
2 High pressure blowers 2 x 2450 m3/h		2	2
Machine length		1645	1645
Connection		4 kW	4kW
Current rating		16 A	16 A
General Data			
Washing nozzles		32	36
Rinse nozzles		10	10
Wash pressure		1	1,3
Pump capacity l/min		950	2 x 620
Wash tank capacity		150	230
Water consumption l/min		8 - 14	8 - 14
Wash pump		2,7 kW	2 x 2,7 kW
Electrical heating of wash tank		2 x 6 kW	2 x 6 kW
Rinse temperature		85°C	85°C
Machinery dimensions			
Wide		720	900
Length		2100	2100
Length with in- and outlet tables		3494	3494
Length with 200 TD connected		5159	5159
Hight		1570	1570



Stainless steel box for small parts
5990-0028: 650 x 530 x 160 mm

EUR 320,-

Stainless steel box for small parts
5990-0029: 650 x 430 x 160 mm

EUR 195,-



JEROS Universal Machine 200

Capacity: approx. 150 - 230 crates pr. hour

Water consumption: approx. 8 - 14 l/min.

Wash tank capacity: 150 l

Voltage connection: 3 x 400 V + N + PE - 50 Hz

Water supply temperature of min. 50° C needed with electrical heating.

Fuses / Max. energy consumption:

- 25 A with a 2,7 kW pump and 2x6 kW heater
- 32 A with a 2,7 kW pump, 2x6 kW heater and 2x9 kW after rinse heater
- 50 A with a 2x2,7 kW pump, 2x6 kW heater and 2x9 kW after rinse heater

JEROS Universal Machine 200 XL

Capacity: approx. 250 - 300 crates pr. hour

Water consumption: approx. 8 - 14 l/min.

Wash tank capacity: 230 l

Voltage connection: 3 x 400 V + N + PE - 50 Hz

Water supply temperature of min. 50° C needed with electrical heating.

Fuses / Max. energy consumption:

- 50 A with a 2x2,7 kW pump, 2x6 kW heater and 2x9 kW after rinse heater



JEROS Drying Unit 200 TD

Capacity: Approx. 150 - 300 Kisten pro Stunde

Voltage connection: 3 x 400 V + N + PE - 50 Hz

Fuses / Max. energy consumption: 16 A

Connection: 4 Kw



The JEROS Create Washers are elements of a module system consisting of:

- Pre-rinse
- Wash
- After rinse and disinfection
- Drying and blowing
- Transport system

For additional information on the system, please contact JEROS.

UK.01.18

UK.01.18



JEROS® A/S

Nyborgvej 8
DK-5750 Ringe

Tel: +45 63 62 39 13
Fax: +45 62 62 33 01

jeros@jeros.com
www.jeros.com

JEROS® A/S

Nyborgvej 8
DK-5750 Ringe

Tel: +45 63 62 39 13
Fax: +45 62 62 33 01

jeros@jeros.com
www.jeros.com